

WGS200C Wall Guard

WGS200 is a modular system comprising PVC-u covers, aluminium retainers and PVC-u accessories. The covers are through coloured and textured to conceal the effects of impact and abrasion. If a wall guard cover gets damaged because of traffic impact, they are replaceable. Features an internal bumper for additional strength and to absorb and dissipate impact. It is designed to provide a tight fit to the wall for minimal dust/dirt trap. Reveals provide tight, neat joints to inhibit the growth of bacteria.

Material:	Cover: PVC-u Retainer: Aluminium
Colour:	Available in 32 colours
Surface finish:	Textured
Thickness of the cover:	2 mm
Height:	200mm
Length:	4,0 m
Accessories:	End-cap, PVC-u cover
Fixing:	Mechanical fixing Screws
Weight:	2,39 kg per m
Fire certification:	B-s2,d0
Resistant to cleaning chemicals:	Yes
Available as BIM object	Yes
Maximum service temp:	60°C

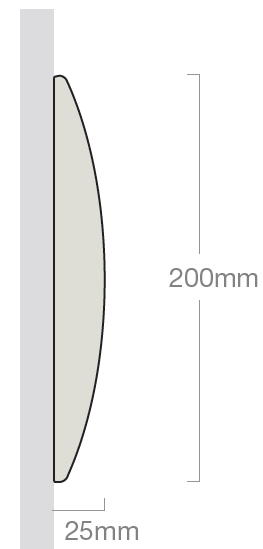
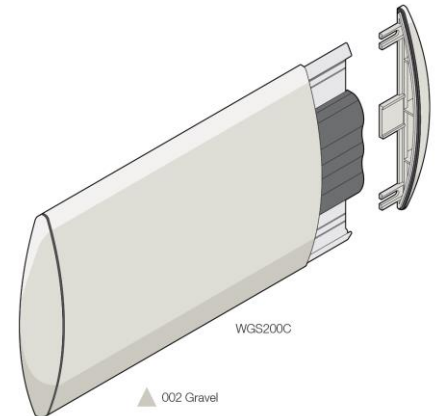

The Gradus WGS200 Wall Guard offers superior direct impact protection against wheeled traffic and incorporates an internal impact bumper to provide reinforced protection and absorption at the point of impact. Modular in design for easy installation and replacement in the event of damage, the WGS200 Wall Guard includes a PVC-u cover, PVC-u inner bumper, aluminium retainer and colour-matched end caps. The continuous retainer provides rigid support for weaker substrates and is ideal for bridging short gaps, recesses and voids. End caps include reveals to provide a tight, neat joint that inhibit the growth of bacteria. All PVC-u covers and accessories are non-reflective, through coloured and textured to conceal the effects of impact and abrasion. Light Reflectance Values (LRVs) and Natural Colour System codes (NCS) are detailed for all colours.

Components



WGS2001
universal end cap
(including reveal)